

2024

DESIGN AND INSTALLATION GUIDE



# AAC Flooring System

---

For Low-rise  
Residential  
Buildings

[walsc.com.au](http://walsc.com.au)



# Contents

<b>01</b>	<b>INTRODUCTION</b>	<b>04</b>	<b>07</b>	<b>DETAILING</b>	<b>10</b>
	1.1 About Walsc			7.1 Floor Framing	
	1.2 What is AAC			7.2 Panel Joints	
	1.3 How is AAC made			7.3 Control Joints	
	1.4 Scope			7.4 Bearing Distance	
	1.5 Limitation			7.5 Edge Distance	
	1.6 Compliance			7.6 Penetrations	
				7.7 Exposure to weather	
<b>02</b>	<b>BENEFITS</b>	<b>05</b>	<b>08</b>	<b>DELIVERY, STORAGE &amp; HANDLING</b>	<b>11</b>
<b>03</b>	<b>MATERIAL PROPERTIES</b>	<b>06</b>		8.1 Delivery	
<b>04</b>	<b>SYSTEM OVERVIEW</b>	<b>07</b>		8.2 Storage & Handling	
<b>05</b>	<b>SYSTEM PERFORMANCE</b>	<b>08</b>	<b>09</b>	<b>PANEL &amp; FLOOR FINISHES</b>	<b>12</b>
	5.1 Structural			9.1 Installation guide	
	5.2 Durability			9.2 Floor Finishes Installation	
	5.3 Fire Resistance			9.3 Plumbing & Electrical services	
	5.4 Acoustic & Energy Efficiency Performance		<b>10</b>	<b>HEALTH &amp; SAFETY</b>	<b>14</b>
<b>06</b>	<b>SYSTEM COMPONENTS</b>	<b>09</b>	<b>11</b>	<b>CONSTRUCTION DETAILS</b>	<b>15</b>

Front cover image courtesy of the Property Owners

## Warranty

Walsc guarantees its AAC products to be free of defect in material and manufacture. Walsc AAC Panel Systems are customised to gain the most satisfaction and guaranteed to offer excellent performance when installed and maintained in line with the latest Design and Installation Guide. Minimum of 20 Years warranty of reinforced Walsc AAC Panel within Walsc AAC Panel Systems from date of purchase are provided to our clients. Further information please call us or visit [www.walsc.com.au](http://www.walsc.com.au)

Walsc is a registered trademark of Sipo Building Solutions Pty Ltd. ABN: 46 614 424 225  
Walsc is a registered trademark of Nanjing Asahi New Building Materials Co., Ltd.

# The Reinforced Walsc AAC Panel is the soul of all our Walsc AAC Panel Systems.

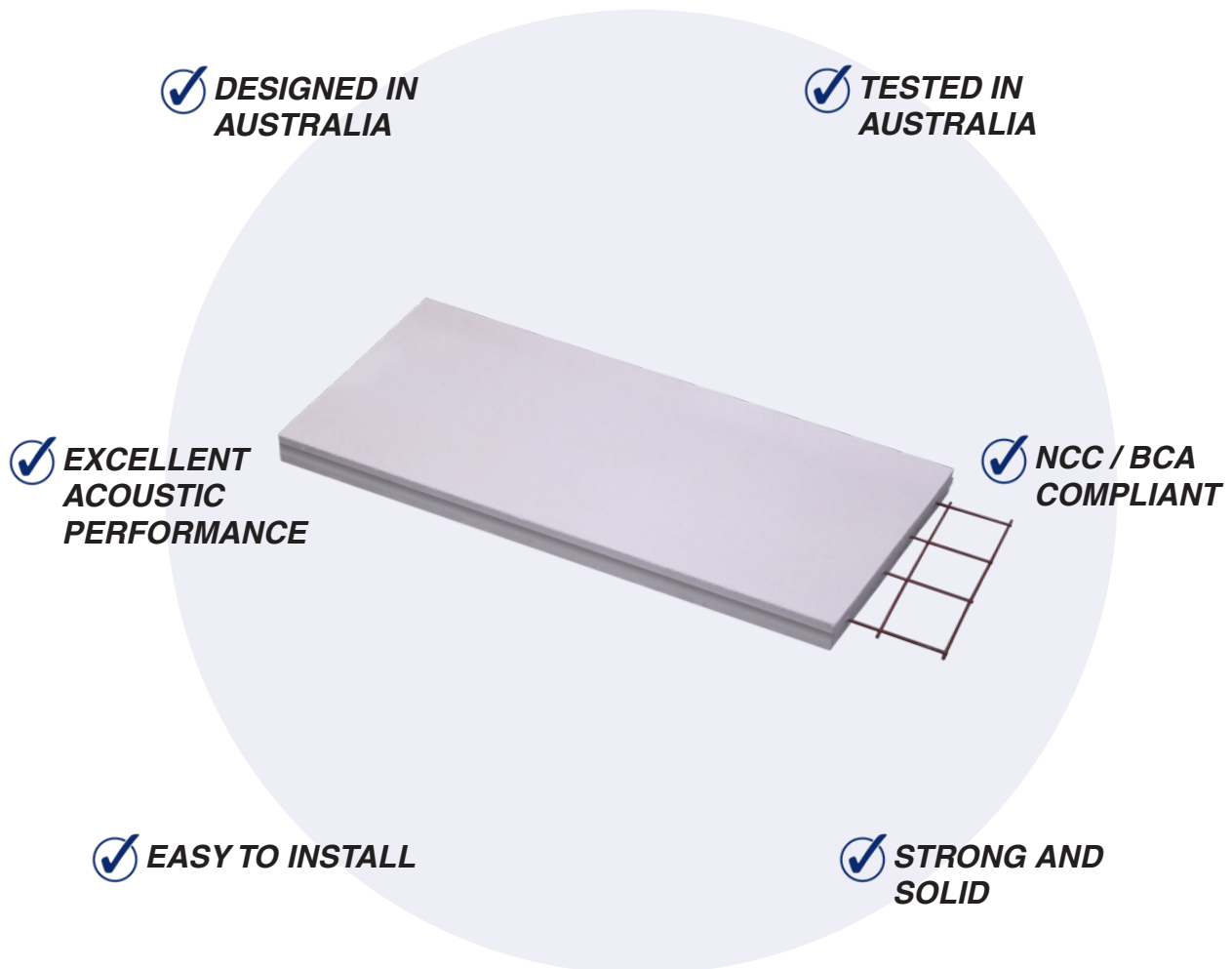

Walsc AAC Flooring System for low-rise residential buildings consists of 1800x600x-75mm T&G reinforced Walsc AAC Floor Panels installed onto a timber or steel joist floor frame. Walsc AAC flooring system delivers unparalleled acoustic performance. It is strong & solid which makes it the excellent base for all the common finishes including carpet, timber strips, and tiles.

**WALSC**<sup>®</sup>  
AAC PANEL SYSTEMS

# 1 Introduction

## 1.1 About Walsc

Walsc AAC Panel Systems (Walsc) provides world leading innovative, top quality autoclaved aerated concrete, AAC products to the market. Our AAC Panel Systems provide high quality, superior performance and cost-effective solutions for wall applications for house and low-rise residential buildings, and also for high-rise commercial and residential buildings. Our AAC Panel Systems are tested and assessed for compliance with the requirements of the building codes of Australia and provide confidence and certainty to regulatory authorities and the market. Walsc was established in 2014 and has become one of the Australia's leading Autoclaved Aerated Concrete (AAC) suppliers. Over the past few years, Walsc has participated in hundreds of projects ranging from low-rise residences, aged care facilities, warehouses to high-rise apartments and commercial buildings. Now Walsc is widely recommended by architects, certifiers and builders because of its premium quality, comprehensive wall and flooring solutions, and strong technical support.

At Walsc, we provide better wall and flooring solutions for your project!

## 1.2 What is AAC?

Autoclaved aerated concrete is manufactured from water, cement, lime, silica sand and a small amount of aluminium powder as expanding agent. The produce techniques impart many unique properties to AAC, making it both economically and environmentally friendly better than other masonry building materials. It can be customised in blocks, wall, floor and roof panels with a range of sizes depending on specific applications, allowing for maximum efficiency and flexibility in construction.

## 1.3 How is AAC Made?

The raw materials are mixed into slurry state and poured into a mould (a very large cake tin). The expanding agent (aluminium powder) instantly initiates a chemical reaction to create numerous tiny and finely-dispersed hydrogen air bubbles. Meanwhile, it causes the mixture to expand to almost twice its original volume. Once the mixture turning is hard enough (semi-solid) to be wire cut into required panel sizes in a heated room, it will be transported into the cutting machine. Then the sliced semi-solid material will be cured with high-pressure

steam in autoclaves for up to 12 hours. During this curing process, the hydration of the concrete is accelerated by the high pressure steam. The combination of the expanding chemical reaction and autoclave curing process gives AAC its unique properties that are beneficial to buildings.

## 1.4 Scope

This guide is intended for use by qualified and experienced architects, engineers and builders for the design, specification and construction of flooring of houses and low-rise residential buildings. These buildings are assumed to be those within the scope of Class 1 & 10 buildings as defined in the National Construction Code - Building Code of Australia (NCC-BCA).

Any variation of the system outlined in this guide is considered outside the scope and must be evaluated by the relevant professional consultant.

## 1.5 Limitation

This guide has been prepared to provide design, installation and technical information for builders, building consultants, engineers and architects. The information relates specifically to Walsc AAC products and must not be used in relation to other building product. The guide does not replace the need for qualified designers (eg. engineers & architects) to specify project specific information and it is their responsibility to confirm the suitability of using Walsc AAC products for a particular project. Walsc Australia/Sipo Building Solutions accepts no liability for errors or omissions in this guide and the user must always check with Walsc to ensure the current edition of the guide is being used.

## 1.6 Compliance

The Walsc 75mm reinforced AAC flooring panel (Walsc AAC Floor Panel) has been tested and assessed to comply with the requirements of the Australian Standard for Reinforced Autoclaved Aerated Concrete Part 3: Construction (AS5146.3-2018). This standard is a secondary reference in Volume Two of the 2019 National Construction Code - Building Code of Australia (NCC) as an acceptable construction guide. This means that provided the installation of the flooring system is in accordance with the AS5146.3-2018, the NCC performance requirement of structural stability and resistance to actions (P.2.1.1) is satisfied.

# 2 Benefits



### Fire resistance

AAC material has earned a reputation for its outstanding fire-resistant properties. It is non-combustible and offers the best fire-resistant performance among any building material currently on the market. In case of fire, it does not release toxic gases and smokes or drip burning materials and prevents spreading of fire.



### Acoustic insulation

Reinforced Walsc AAC Panel is proven to be an extraordinary acoustic insulation material by building a defence against external noise pollution. Its sound insulation value is greater than other materials of the same weight.



### Thermal insulation

The low thermal conductivity along with thermal mass gives the reinforced Walsc AAC Panel high R-values. These thermal efficiencies reduce energy costs by eliminating the original reliance on cooling and heating appliances.



### Compliance Assured

The wall systems have been accredited CodeMark Certification and all systems are undergoing continuous testing by NATA accredited laboratory to ensure its compliance with various requirements especially in fire resistance and acoustic insulation.



### Strong & Durable

Reinforced Walsc AAC Panel enhances the strength and security by combining with the corrosion protected steel, the durability is quite similar to concrete.



### Eco-friendly

All the ingredients contained in the reinforced Walsc AAC Panel are natural and toxic-free which also means no pollutant and toxic gases will be generated during the manufacture and installation. Even the scrap material that is produced during the utilisation can be recycled.



### Fast Construction

Panelised Walsc AAC products with flat packed delivery remarkably contribute to the speed of construction. It enables laborers to install much more square footage of AAC than that of traditional masonry materials within the same period of time, promoting the efficiency during the entire lifetime of the project.



### Technical Support

We offer sales services, technical advice and support to meet the satisfaction. We actively cooperate with our customers to ensure the project is completed smoothly.

# 3 Material Properties

For flooring system used in low-rise residential buildings, Walsc supplies one thickness of reinforced AAC panel (75mm) which is compliant with the requirements of AS5146.3-2018. The panel is 1800mm long by 600mm wide and consists of a single layer of steel reinforcement located centrally in the panel thickness. The long edges of the panel incorporated a tongue and groove profile to enable load sharing between adjacent panels. The ends of each panel are square without tongue and groove.

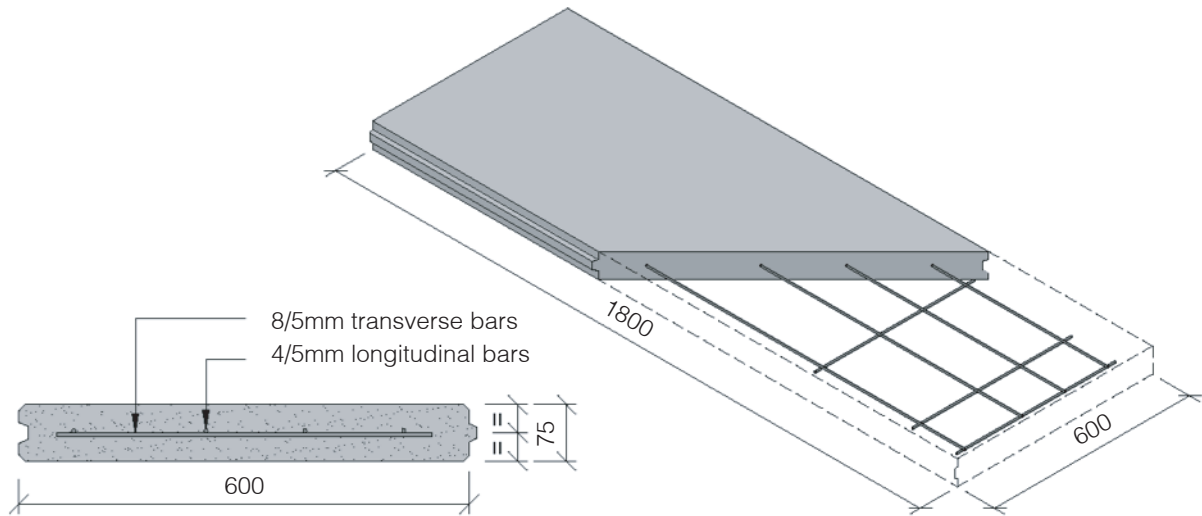

**Fig 1. Panel Details**

The table below outlines the material properties of reinforced Walsc AAC Floor Panel.

**Table 1. Material Properties**

Property			Value
Panel Thickness	$d$	(mm)	75
Panel Width	$w$	(mm)	600
Panel Length	$L$	(mm)	1800
Panel Edge Profile			Tongue & Groove
Ultimate Strength Bending Capacity <sup>(1)</sup>	$\phi M_K$	(kNm/m)	0.696
Dry Density	$\rho_m$	(kg/m <sup>3</sup> )	525
Declared Density Class	$\rho_{m,g}$	(kg/m <sup>3</sup> )	600
Declared Tolerance of Dry Density	$\Delta\rho_g$	(kg/m <sup>3</sup> )	+/- 50
Characteristic AAC Compressive Strength	$f_{ck}$	(MPa)	3.0
Density for Structural Design	$\rho_{d,sup}$	(kg/m <sup>3</sup> )	678
	$\rho_{d,inf}$	(kg/m <sup>3</sup> )	568
Coefficient of Thermal Expansion			(x10 <sup>-6</sup> /K) 7.0
Tensile Yield Strength	$f_{yk}$	(MPa)	500
Characteristic Weld Strength	$V_{uk}$	(kN)	3.1

**Note:**

(1) Refer to structural report prepared by VENN Engineering Pty Ltd reference VE-SIP181005v1 dated 05/10/2018.

# 4 System Overview

The Walsc AAC Flooring System for low-rise residential buildings consists of 75mm reinforced Walsc AAC Floor Panels installed onto a timber or steel joist floor frame. Construction adhesive is applied to the top of the joists prior to the panel being laid and fixed using screws embedded into the joists. All panel edges in contact with another panel require a 2-3mm panel adhesive joint except where control joints are required.

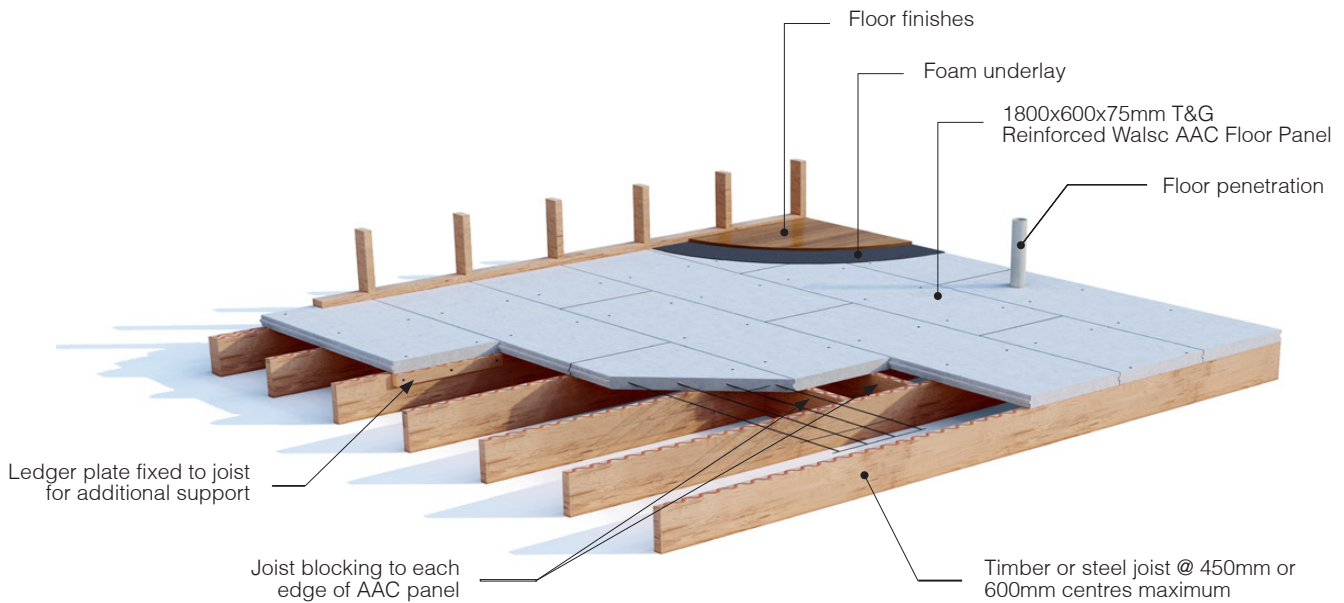

**Fig 2. Walsc AAC Flooring System Overview**

The table below outlines the suitable floor finishes option . For alternatives not shown in the table, contact Walsc for more information.

Finish	Sub-layer	Top-layer
Carpet	Medium duty carpet underlay	Selected carpet
Vinyl 1	Masonite underlay (min. 3mm thick) screw fixed to AAC floor panels	Vinyl sheet floor
Vinyl 2	Screeded concrete (mini. 5mm thick)	Selected vinyl fixed to concrete using flexible adhesive
Timber 1	PVC sheeting with battens over	Timber strip flooring fixed to battens
Timber 2	PVC sheeting with foam underlay over	Floating timber floor
Tile 1	Waterproof membrane (only required at wet area) in accordance with AS3740	Selected tiles fixed to waterproof membrane using flexible adhesive
Tile 2	Waterproof membrane in accordance with AS3740 with concrete topping slab (50mm) over	Selected tiles fixed to topping slab using flexible adhesive

# 5 System Performance

## 5.1 Structural

The Walsc AAC Flooring System is suitable for supporting 2.0kPa uniformly distributed imposed loading and 1.8kN concentrated imposed loading as required by AS1170.1 for housing. For these loads the reinforced Walsc AAC Floor Panels are capable of spanning across timber or steel floor joist system where the maximum spacing of the members is 600mm. The supporting floor framing system (bearers and joists) is required to be in accordance with the relevant standard, AS1720.1 for timber or AS4600 for steel. Designers must ensure that self-weight of reinforced Walsc AAC Floor Panel and floor finishes is taken into account when designing the floor framing systems.

Stacked materials shall not be located on any floor panel installation without confirmation from a structural engineer.

For the support concentrated loadings, e.g. 1.8kN applied over 350mm<sup>2</sup> area, a suitable floor finishes shall be provided on top of the reinforced Walsc AAC Floor Panels. Suitable finishes include those listed in the System Overview section.

## 5.2 Durability

AAC has a proven record as a durable material against the Australian environment since its introduction over 30 years ago. The reinforcement in all reinforced Walsc AAC Floor Panels has a corrosion resistant coating applied for corrosion protection. Where a reinforced Walsc AAC Floor Panel is cut, the exposed reinforcement must be treated with anti-corrosion paint. Provided that all surfaces of the 75mm reinforced Walsc AAC Floor Panel are installed for an internal environment, no additional corrosion protection measures are required.

For external flooring applications like decks and verandas, the

top surface of all 75mm reinforced Walsc AAC Floor Panels shall have a coating or membrane in accordance with section 2.8.4 of 2.8.5 of AS5146.3 and be compatible with the selected floor finishes. The underside of the 75mm reinforced Walsc AAC Floor Panels shall also be protected which can be achieved by enclosing the sub-floor perimeter of the deck/veranda.

The corrosion protection of the screw fixings must also be suitable for the particular exposure environment shown in the table below.

It is the designer's responsibility to confirm the suitability of the flooring system for the environment of each specific site.

## 5.3 Fire Resistance

The Walsc AAC Flooring System provides 240 minutes fire resistance against fire sources above the floor. Where fire resistance is also required from below, a fire rated ceiling system will need to be installed.

For all fire rated applications, all penetrations shall be sealed using proprietary fire collars and the sealants used in control joints shall be 4-hour fire rated. Compliance with fire rating requirements shall always be confirmed by a qualified and experienced fire engineering consultant.

## 5.4 Acoustic & Energy Efficiency Performance

The Walsc AAC Flooring System provides significant insulation against sound transmission and heat loss/gain through the floor. The acoustic and energy performance of 75mm AAC flooring system in a low-rise residential building with various floor finishes is detailed in section 6.3.1 of AS5146.3-2018. Contact Walsc for further information.

**Table 2.** Screw Fixing Corrosion Requirements

Category	Corrosion Environment description	Screw fixing corrosion class
<b>Mild</b>	More than 10km from breaking surf	Class 3 in accordance with AS3566.2
<b>Moderate</b>	1 to 10km from breaking surf	Class 3 in accordance with AS3566.2
<b>Marine</b>	100m to 1km from breaking surf	Class 4 in accordance with AS3566.2
<b>Severe Marine</b>	within 100m of breaking surf	Grade 304 or 316 stainless steel

# 6 System Components

**Table 3.** System Components

Product	Description	
Reinforced Walsc AAC Floor Panel	The panels have tongue and groove edges along the length and are 1800x600x75mm in size.	
AAC Panel Screw	For timber joists use 14-10x100mm type 17 hex or bugle head screws and for steel joists use 14-10x95mm self-drilling hex or bugle head screws. All screws shall be Class III corrosion resistance (minimum) as per AS3566.2-2002.	
Floor Framing	Timber or steel joists framing shall be designed in accordance with AS1720.1-2010 or AS/NZS 4600:2005 respectively.	
Walsc AAC Adhesive	Thin-bed adhesive used for panel joints is to be C1E classification in accordance with AS ISO 13007.1. Its application shall be to all adjoining panel edges (except for control joints) and can also be used to patch up minor damaged areas.	
Corrosion Protection Paint	When panels are cut, the exposed ends of the reinforcement must be treated with corrosion protection paint.	
Sealant	An external grade polyurethane sealant must be used in all control joints.  For non-fire rated applications, recommend to use Bostik Seal 'N' Flex 1 or equivalent.  For fire rated applications, recommend to use Bostik Fireban One, H.B. Fuller Firesound or equivalent.	
Construction Adhesive	Construction adhesive is applied to the top of the joists. Ensure the surface is clean and dry. Free from all loose paint, dust and contamination.	

# 7 Detailing

## 7.1 Floor Framing

The floor framing that supports the reinforced Walsc AAC Floor Panel shall be in accordance with the relevant standard; AS1720.1-2010 for timber or AS/NZS4600:2005 for steel. Deflections of the floor framing shall be limited to span/400.

For domestic applications where the imposed floor loading does not exceed 2.0kPa uniformly distributed or 1.8kN point load (applied over 350mm<sup>2</sup>), the maximum spacing of the floor joists shall be 600mm.

## 7.2 Panel Joints

All joints between panels, except at control joint locations, shall contain Walsc AAC Adhesive that is applied evenly across the full area of the adjoining panel edge to form a 2-3mm joint. Walsc AAC Adhesive is defined in the system components, refer to Table 3.

## 7.3 Control Joints

Control joints in the flooring system shall be provided to allow for movement in the building. As a minimum, control joints shall be located:

- At changes of direction in joists/panels (see Figure 11);
- As cover supports where supporting joist is also supporting load bearing walls (see Figure 12);
- At the intersection of different flooring framing materials;
- At locations of movement joints in the supporting structure (eg. slab joints);
- At not more than 8m centres.

## 7.4 Bearing Distance

All panels shall have a bearing width of 25mm. Where the framing system does not provide sufficient bearing width for a

reinforced Walsc AAC Floor Panel, additional framing shall be provided, ledger plates or joist blocking (see Figure 6 and 7).

## 7.5 Edge Distance

The minimum edge distance for fixing Walsc AAC Floor Panels shall be 20mm from the ends of panels and 100mm from the sides of panels. Fixings shall not be installed in rebated or chamfered edges of panels. The minimum panel width shall be 200mm and containing a minimum 2 longitudinal steel bars.

## 7.6 Penetrations

All penetrations shall be cut through the reinforced Walsc AAC Floor Panel using concrete coring tools or similar. For penetrations greater than 80mm or where a longitudinal reinforcement bar has been cut during the coring stage, joist blocking shall be provided to each side of the penetration (see Figure 9). A 10mm gap shall be provided around the penetration and filled with sealant and backing rod.

Where the flooring system is required to be fire resistant, the sealant shall be 4-hour fire resistant or alternatively, a fire collar system shall be installed around the penetration. All fire sealing details shall be confirmed by the project fire engineer during the design stage as well as construction.

## 7.7 Exposure to Weather

When installed, reinforced Walsc AAC Floor Panels can be exposed to the weather for a short period (less than 3 months). Where reinforced Walsc AAC Floor Panels become wet during this exposure period, the installation must be given sufficient time to dry out and reach an equilibrium moisture content prior to floor finishes being installed.

# 8 Delivery, Storage & Handling

## 9.1 Delivery

Before delivery of reinforced Walsc AAC Floor Panels on site, an appropriate unloading area should be designated. The unloading area should be:

- Capable of supporting the weight of the reinforced Walsc AAC Floor Panel packs. Consult the project's structural engineer if required.
- On level support, and elevated off any surface that may have water run across it (e.g. outside ground, interiors without roofing).
- Kept dry either by storing inside, or protected from the rain (e.g. by use of plastic wrapping).
- Large enough to contain all panels for the construction stage without stacking packs on top of each other.
- As close as possible to the installation area, to minimise the additional lifting required. This may mean designating additional unloading areas depending on the project size.

## 9.2 Storage & Handling

Wherever possible, reinforced Walsc AAC Floor Panels should have the faces, corners and a edges protected from damage. Whenever moving panels, the following precautions should be taken:

- Before lifting packs, ensure that the panels are securely strapped.
- Personnel operating lifting machinery (e.g. forklifts, cranes, trolleys) must use the appropriate techniques and equipment.
- When opening packs, appropriate measures should be taken to prevent panels from falling.
- Any opened packs are protected from the weather and secured while not in use.
- All workers have appropriate personal protection equipment (PPE) for the worksite conditions. Recommended PPE includes but is not limited to:
  - Hearing & eye protection

- Safety clothing (e.g. safety boots, well-fitting clothing)
- Respiratory protective equipment
- Sun protection (e.g. hats, long sleeves, trousers, sun screen).

- All workers are trained in an appropriate manner for the tasks undertaken. For example, proper equipment maintenance and usage, material safety and good lifting techniques would fall into this category.
- The sequence of installation should be planned to minimise panel movements and ensure installers will have appropriate room to lift the panels.
- Whenever manually lifting single panels, a minimum of two people should carry each panel and the panel should be carried on its side (not flat). Good lifting techniques (detailed below) and a clean worksite should be maintained to minimise injuries.

## 9.3 Good Lifting Techniques

There is no proven 'best' way of lifting, as it will vary with the weight and shape of the object being lifted. The better options available are a 'deep squat' and 'semi squat' lift. The deep squat is done by bending the knees and hip to their maximums, while keeping the upper body approximately vertical. The semi squat is done by leaning the upper body forwards as a whole (while keeping the spine straight) and bending the legs to a lesser degree than the deep squat.

The basic principles of good lifting are to:

- Minimise the distance between the load and the body
- Bend the knees, allowing for use of the leg muscles
- Keep the back as Straight as possible

For more details refer to the relevant state based safety regulation documentation (e.g. Safe Work Australia).

# 9 Panel & Floor Finishes

## 8.1 Panel Installation Guide

### *Prior to any construction*

1. Ensure the work area is clean and tidy prior to commencing work.
2. Confirm that all system components obtained for the installation are those listed in the System Components section of this guide.
3. Confirm the uniformly distributed and concentrated load requirements for the installation and select the floor finishes system.

### *Preparing for panel installation*

4. Ensure the floor framing system has been completed to the point of being ready for installation of the panels. This includes checking that the framing is straight and level.
5. Plan the panel installation, starting from one corner allowing for control joints as per the Control Joints section of this guide or as specified by the project engineer.
6. Where the bearing width of a panel on a joist is less than 25mm, install a ledger plate to increase the bearing width (see Figure 6). Where the end of a panel occurs in between two joists, provide joist blocking as (see Figure 7).
7. Provide joist blocking to each side of a penetration that is larger than 80mm in diameter.

### *Installing the first panel*

8. Apply construction adhesive to the joists where the first panel is to be installed.
9. Install panel onto joists ensuring the panel is aligned to the floor framing.
10. Screw fix panel to joists using two screws per joist per panel. Ensure screws are embedded 5mm into panel face.

### *Installing subsequent panels*

11. Apply construction adhesive to the joists where the subsequent panel is to be installed.
12. Apply panel adhesive, approximately 2-3mm thick, along the full edge to be joined. Where the panel joint is a control joint, instead leave the edges of the reinforced AAC panels clean and create a 10mm nominal gap.
13. Install the subsequent panel onto the supporting joists and push it up against the previously installed panel.

14. Screw fix panel to joists using two screws per joist per panel. Ensure screws are embedded 5mm into panel face.
15. Scrap excessive adhesive from joint and use it to patch the screw head holes.
16. Repeat the above steps for all further panels ensuring that the panel end joints are offset by at least 450mm, preferably 900mm (stretcher bond pattern).

### *Floor finishing*

To reduce the risk of damage occurring to the reinforced Walsc AAC Floor Panel prior to the floor finishes being installed, it is recommended to temporarily cover the panels with a plywood or similar material.

## 8.2 Floor Finishes Installation

### *Floor preparation*

Firstly, ensure the reinforced Walsc AAC Floor Panel is clean and dry for installing covering. All debris and loose particles should be removed, screw holes, dents and cracks on the panel should be patched and repaired with Walsc AAC Adhesives.

Once the panel is ready, floor finishes can then be installed.

### *Carpet*

Underlay and carpet shall be installed as per manufacturer's requirement. Medium or heavy duty underly should be used.

Carpet gripper should be installed in accordance with AS/NZS2455.1, with 51mm dome head twist nail, or T17 point coarse thread 50mm countersinking screws to fix down to AAC panel.

### *Vinyl*

Vinyl should not be installed directly onto panel, concrete screed or Masonite should be between panel and vinyl.

In case concrete screed is used, sealer should be used on the panel and applied as per manufacturer's requirements. If it is at the wet area, waterproof membrane is required after sealer, then vinyl is installed as per standard practice.

In case Masonite is used, Masonite can be fixed directly with 51mm dome head twist nail (coarse thread) to panel, the head of the twist nail should finish with Masonite, then vinyl is installed as per standard practice.

### *Tiles*

Sealer should be used on the panel and applied as per manufacturer's requirements. If it is at the wet area, waterproof membrane is required after sealer.

After the sealer and waterproof membrane, tiles can be fixed with flexible direct stick adhesives, or to concrete screed/ concrete topping slab as per manufacturer's requirement.

Note that control joint should be left on tiles along the panel control joints (see Section 7.3), no matter the concrete screed or concrete topping slab is used or not.

### *Timber*

Floating timber floor can be installed with underlay as per standard practice.

Timber strip flooring is used, it is recommended to use direct mechanical fixing with 12mm plywood sheets to the panel

with minimum 65mm coarse thread countersink screws at max 600mm centres.

### *Epoxy*

Epoxy flooring or coating shall NOT be used on AAC floor.

### **8.3 Plumbing & Electrical Services**

Holes for penetrations shall be cut using drills or coring tools suitable for cutting through concrete. Ensure all penetrations are sealed using sealant and backing rod to form a 10x10mm joint. Use fire rated sealant or fire collars for fire rated applications in accordance with the project specifications. Chasing of reinforced Walsc AAC Floor Panels is strictly prohibited in any application as it is likely to reduce the structural integrity of the panel.

# 10 Health & Safety

Reinforced Walsc AAC Floor Panels, like all concrete members, contain crystalline silica (also known as silica dust). Prolonged exposure via inhalation can cause silicosis in the long term, among other possible conditions. As such, proper PPE usage during construction is necessary to create a safe work environment.

While AAC panels are left undamaged and intact, there is no potential health risk. As such, touching the material with bare skin is not an immediate problem. Protection may be suitable however, to prevent abrasion from skin contact. However, when the material has been broken down by any process such as cutting, drilling, chasing or sanding silica dust is generated. As such, this generates an increased risk of health problems. Long term exposure increases this risk, so it is advised that precautionary measures are taken.

Either protective masks or dust extraction are recommended for usage as a preventative measure during any process that breaks down the panels. Wet cutting of the panels is not recommended. Protective respirators should be of Class P1

or P2 (to AS/NZS1715 and AS/NZS1716) and recommended for dust, at a minimum. Dust extraction systems should be appropriately filtered as required by local council regulations. The site should also be cleaned at regular intervals (e.g. daily) to prevent dust accumulation.

Other preventative measures not related to the inhalation of silica dust may include:

- Eye protection in accordance with AS1336
- Protective footwear in accordance with AS2210
- Ear plugs/ear muffs to an appropriate rating for the tools being used, in accordance with AS1270
- Protective clothing such as long sleeve shirts and trousers, or overalls to prevent possible skin irritation. This will also have the added benefit of protecting outside workers from the sun.

**For further details, see the MSDS at [www.walsc.com.au](http://www.walsc.com.au).**



**SAFETY ALWAYS COMES FIRST, WEAR PPE!**

# 11 Construction Details

Figure	Construction Details Overview	Page
3	Edge Fixing Detail	16
4	Fixing Detail	16
5	Panel End Joint Fixing Detail on Double Joist	16
6	Panel End Joint Fixing Detail on Double Joist	16
7	Panel End Joint Fixing Detail on Joist Blocking	17
8	Pipe ( $\Phi$ 80mm max.) Penetration Detail	17
9	Pipe ( $\Phi > 80$ mm) Penetration Detail	17
10	Control Joint Detail	18
11	Control Joint Detail at Change in Direction of Joists	18
12	Control Joint Detail Where Joist Span is Supporting Load Bearing Walls	18
13	Load Bearing Wall Support Detail on Double Joist	19
14	Load Bearing Wall Support Detail on Joist Blocking	19
15	External Wall Support Detail	20
16	External Brick Veneer Wall Support Detail	20
17	Fitted Floor Panel at Internal Wall Detail	21
18	Fitted Floor Panel at External Wall Detail	21
19	Blocking Detail for Corner Notching	22
20	Wet Area Detail	23
21	Shower Area Detail	23

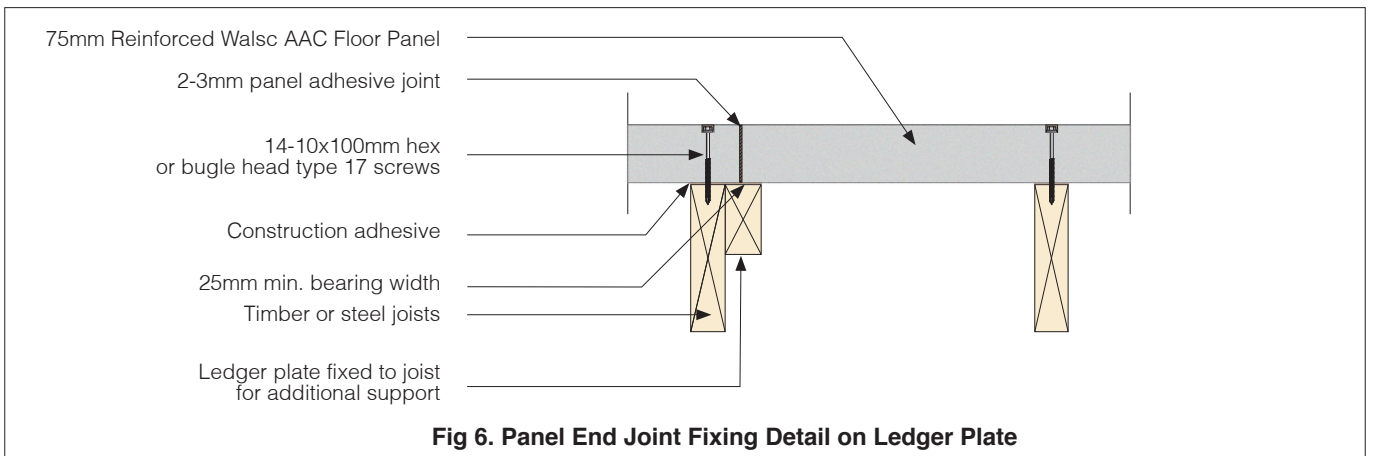
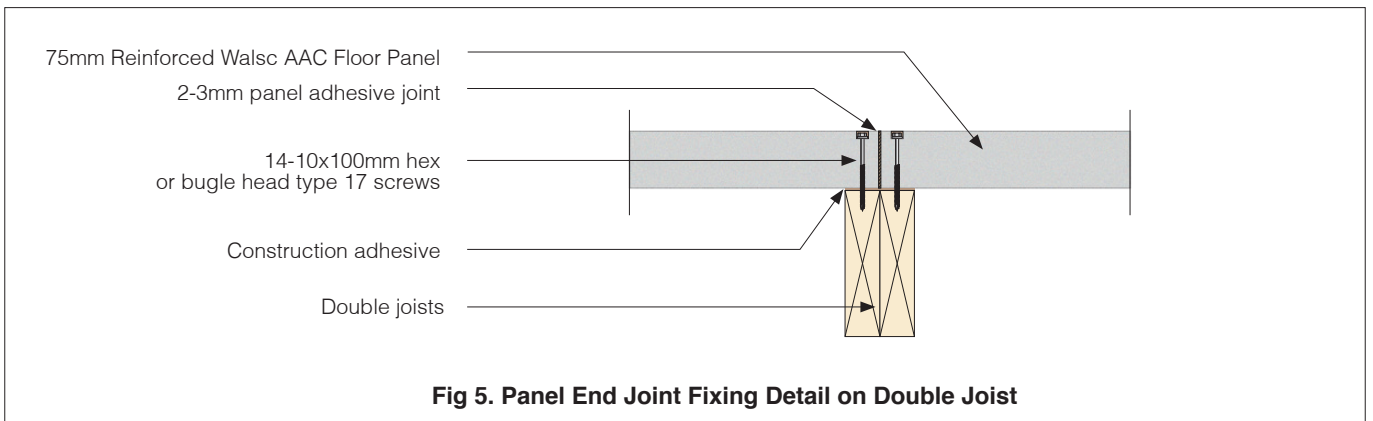
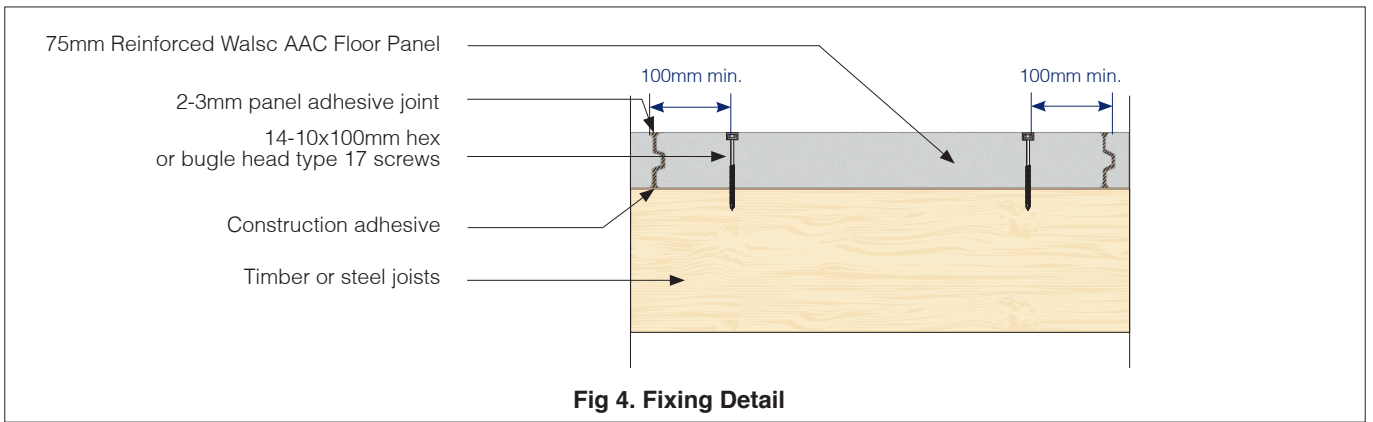
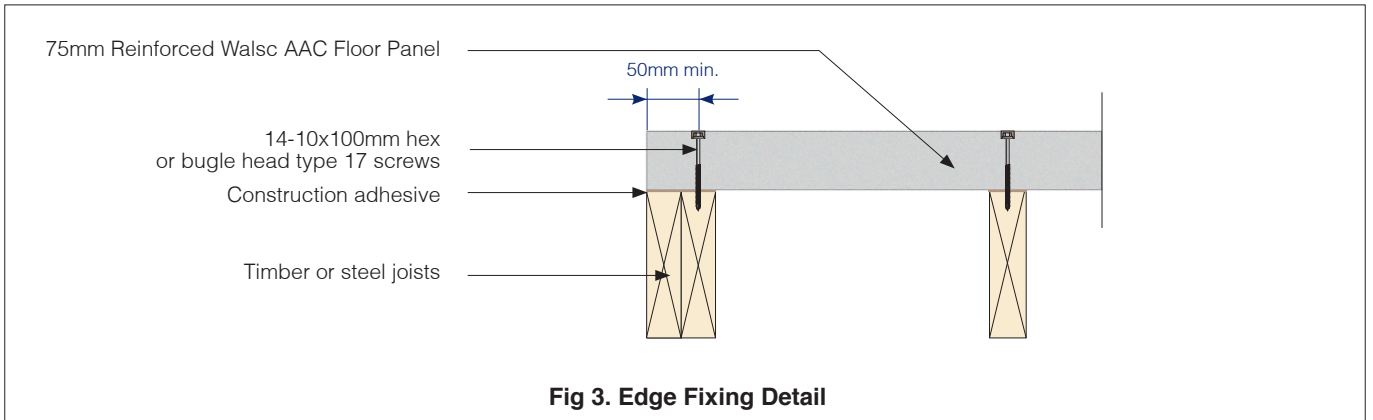

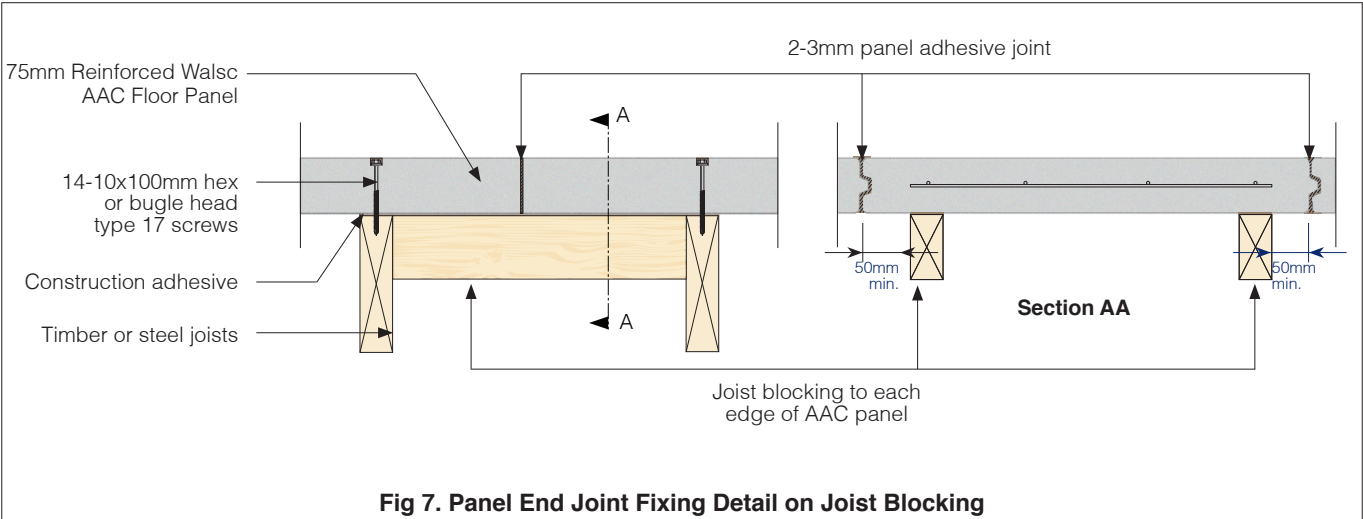

Fig 7. Panel End Joint Fixing Detail on Joist Blocking

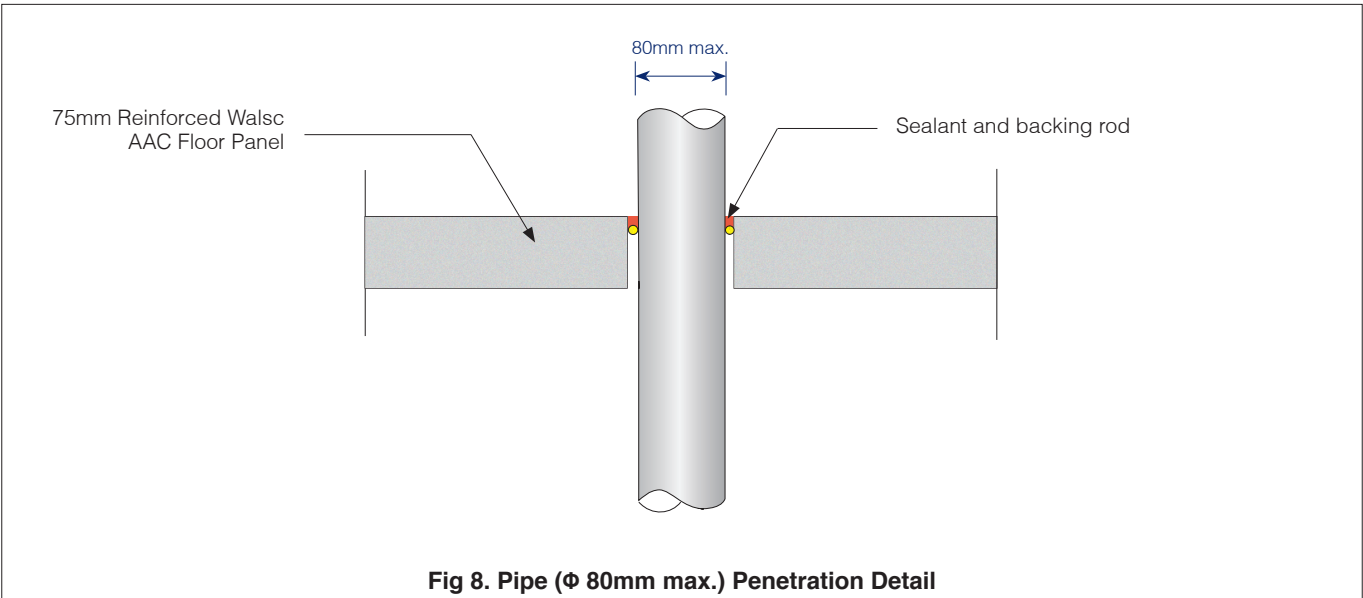

Fig 8. Pipe (Φ 80mm max.) Penetration Detail

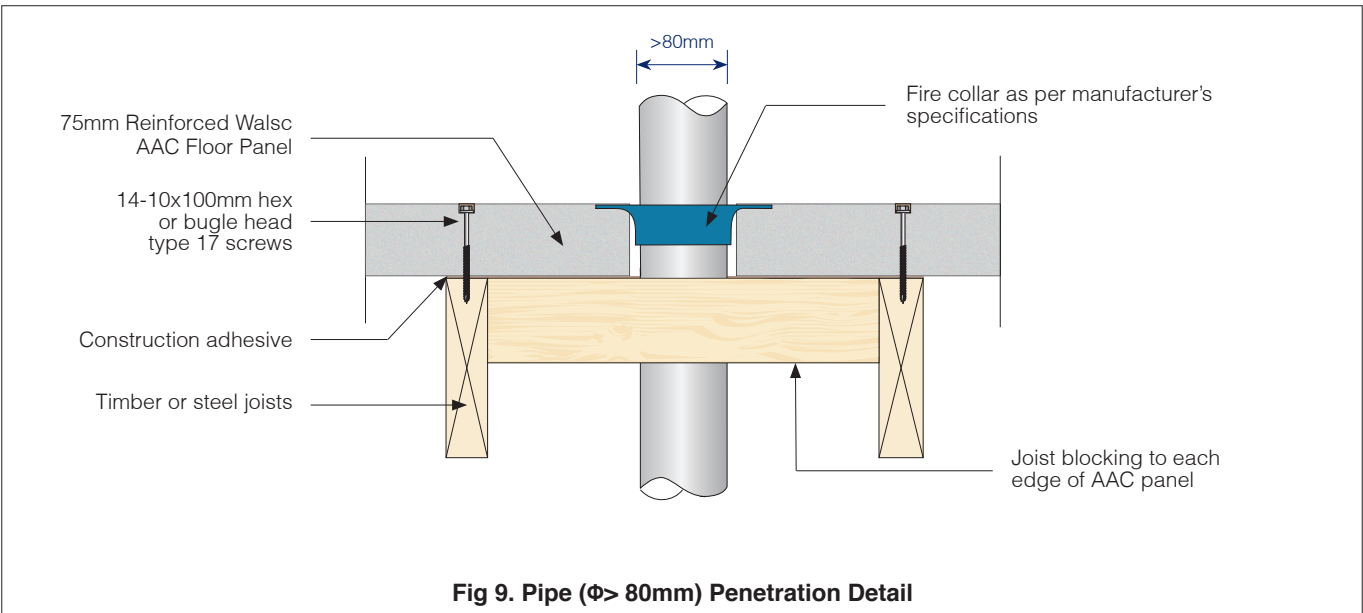
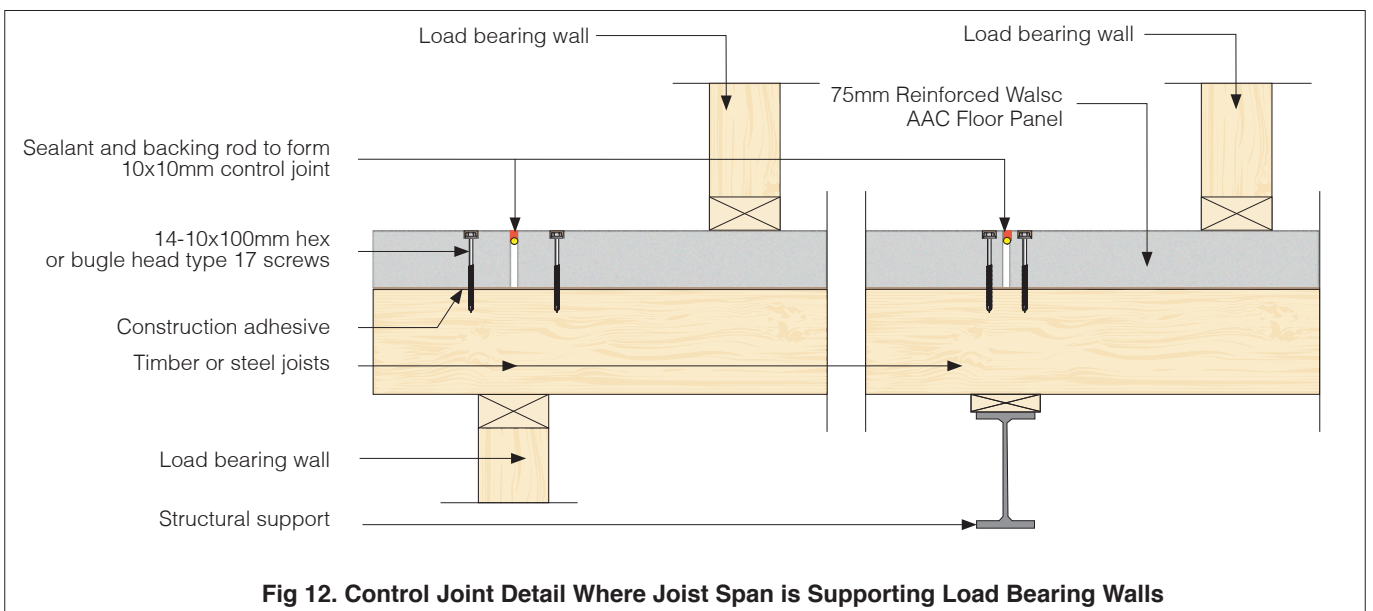
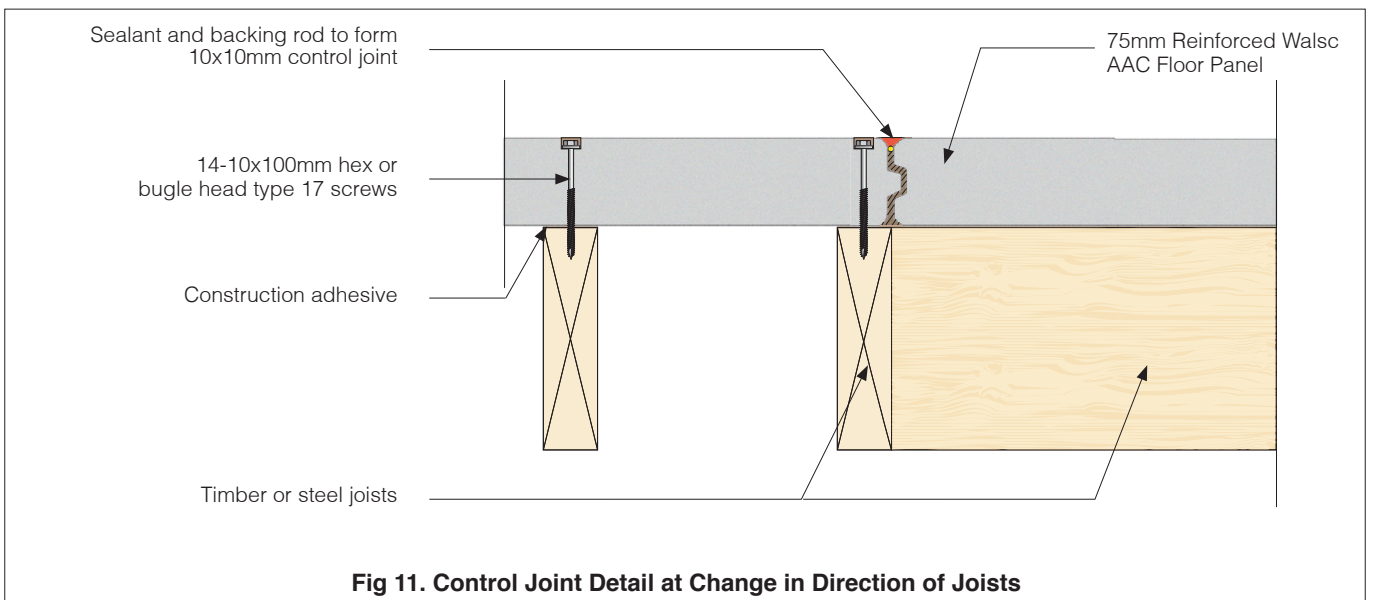
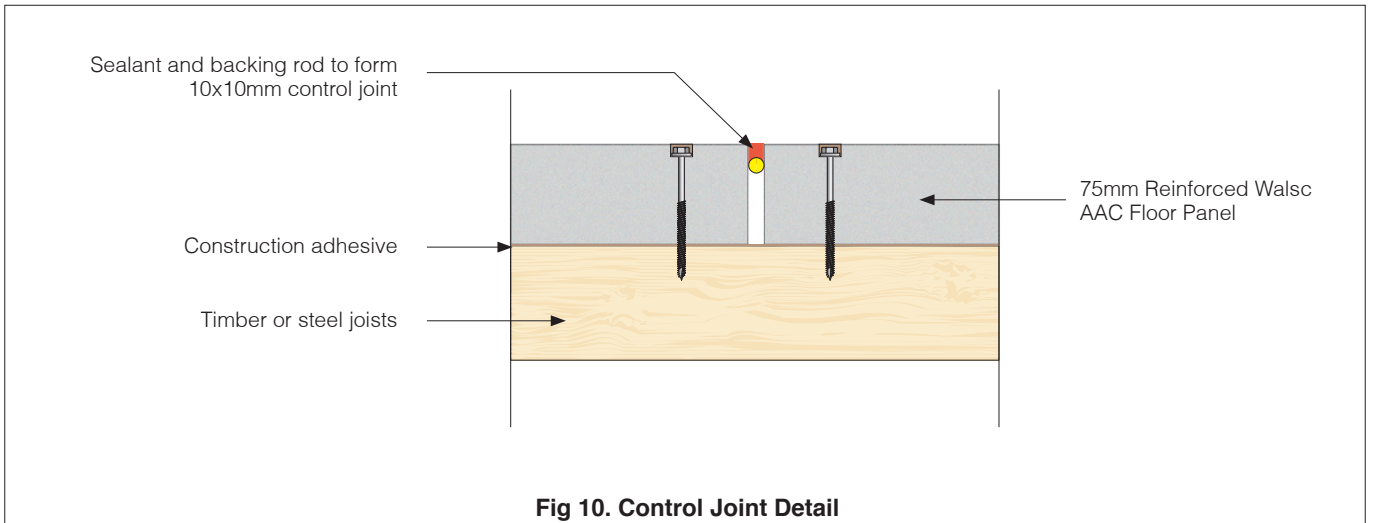
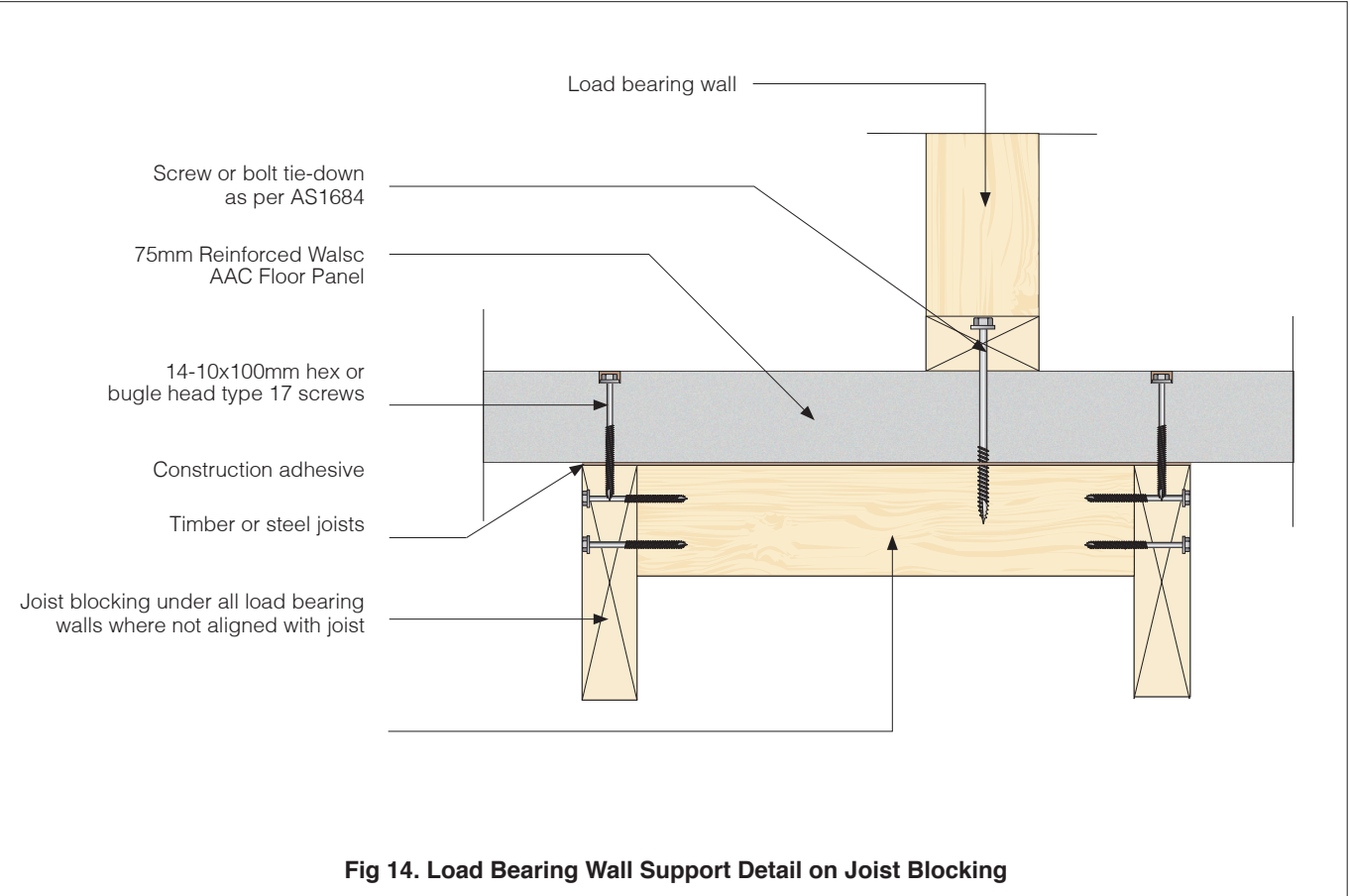
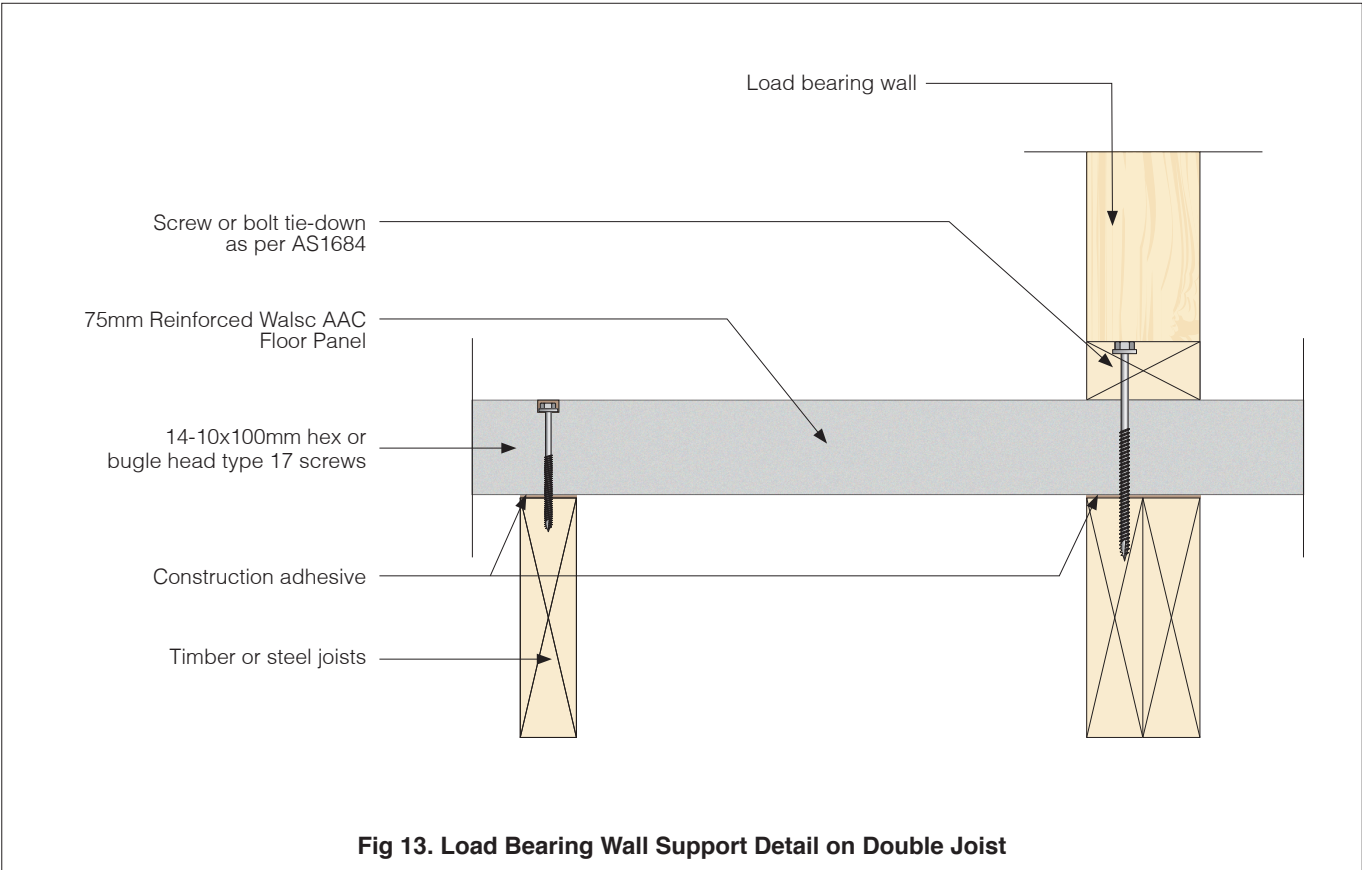
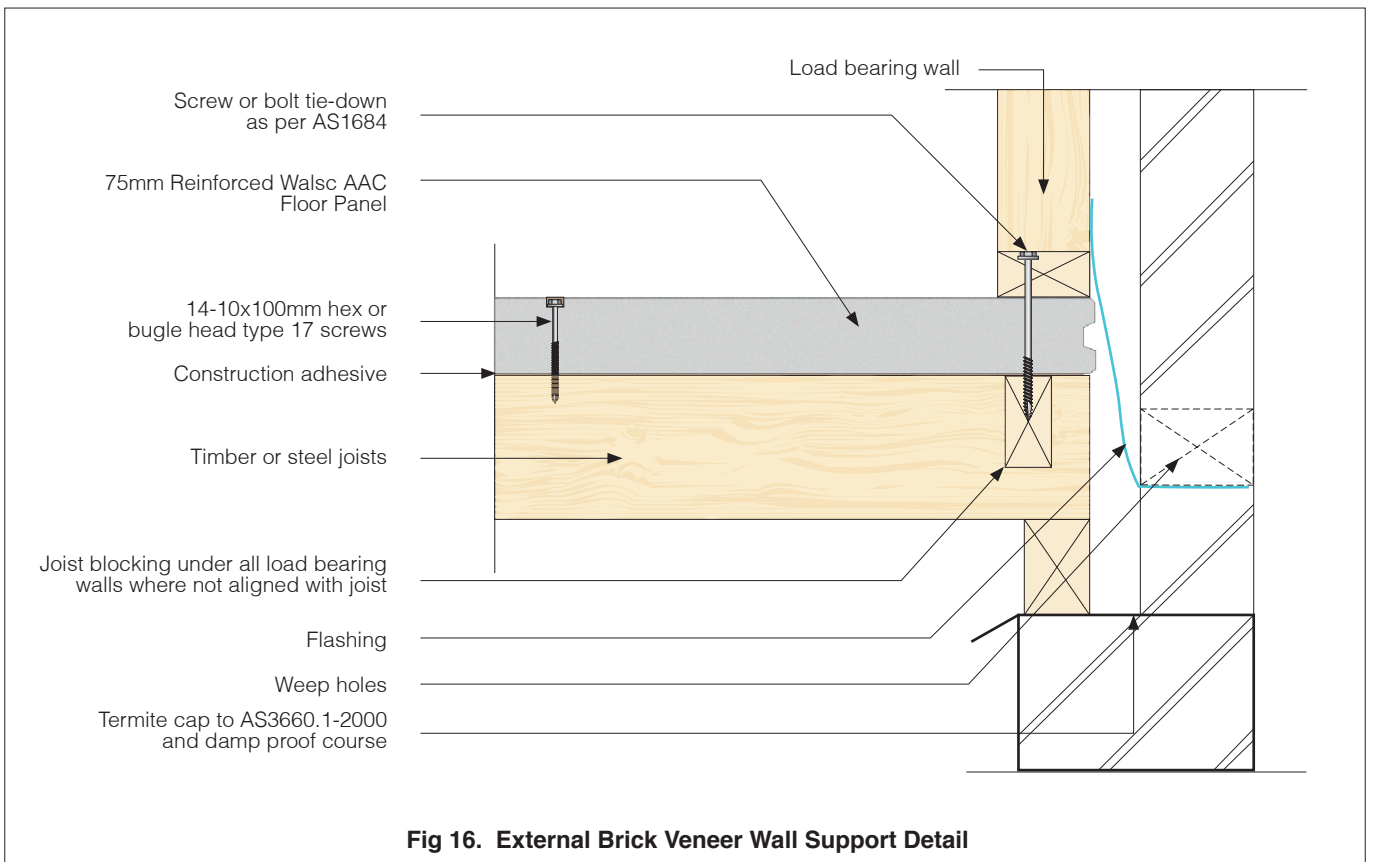
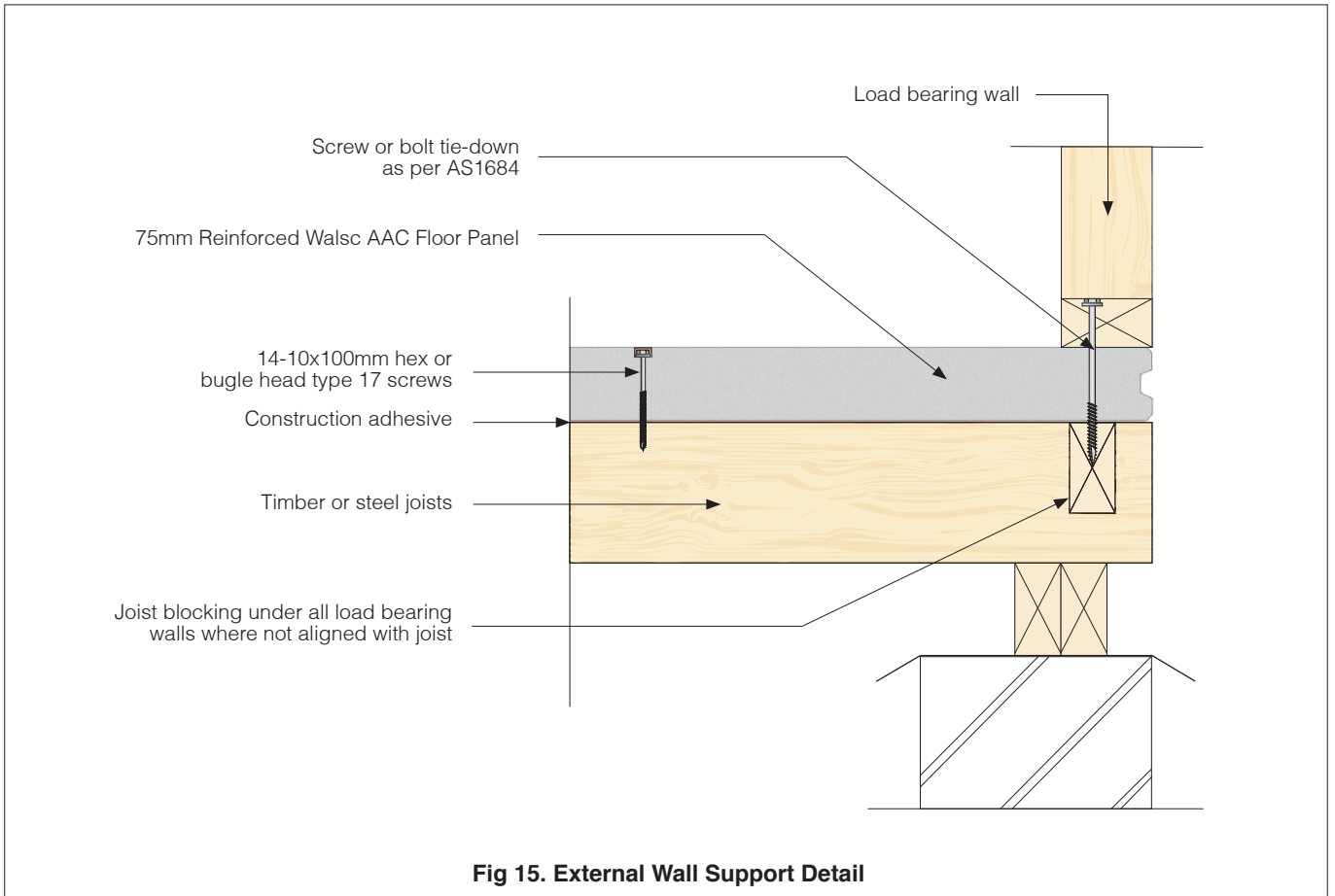

Fig 9. Pipe (Φ > 80mm) Penetration Detail







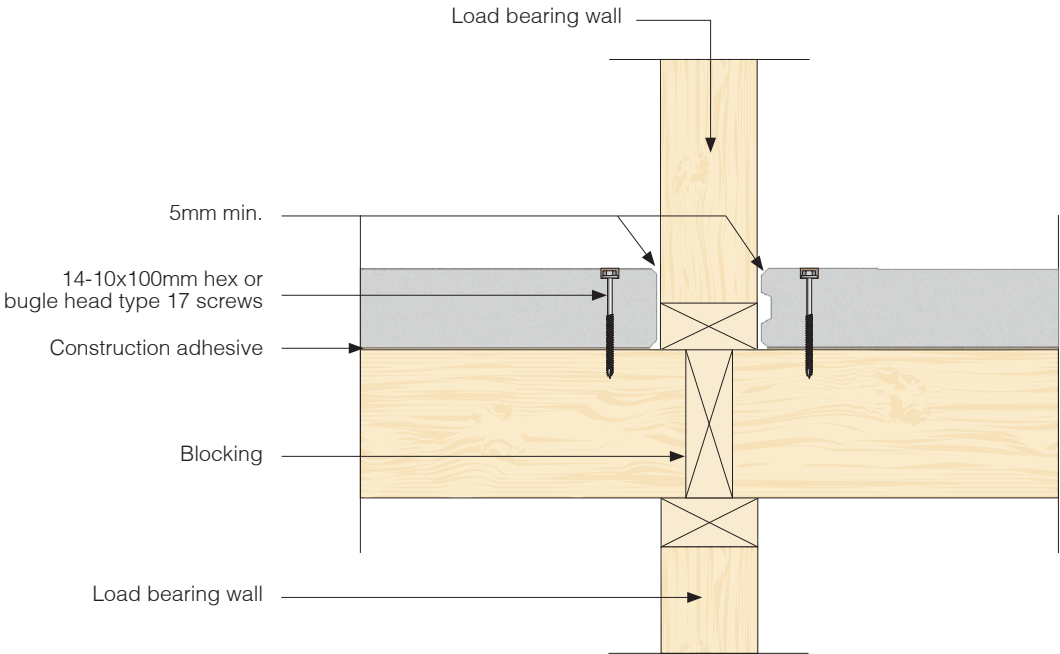

Fig 17. Fitted Floor Panel at Internal Wall Detail

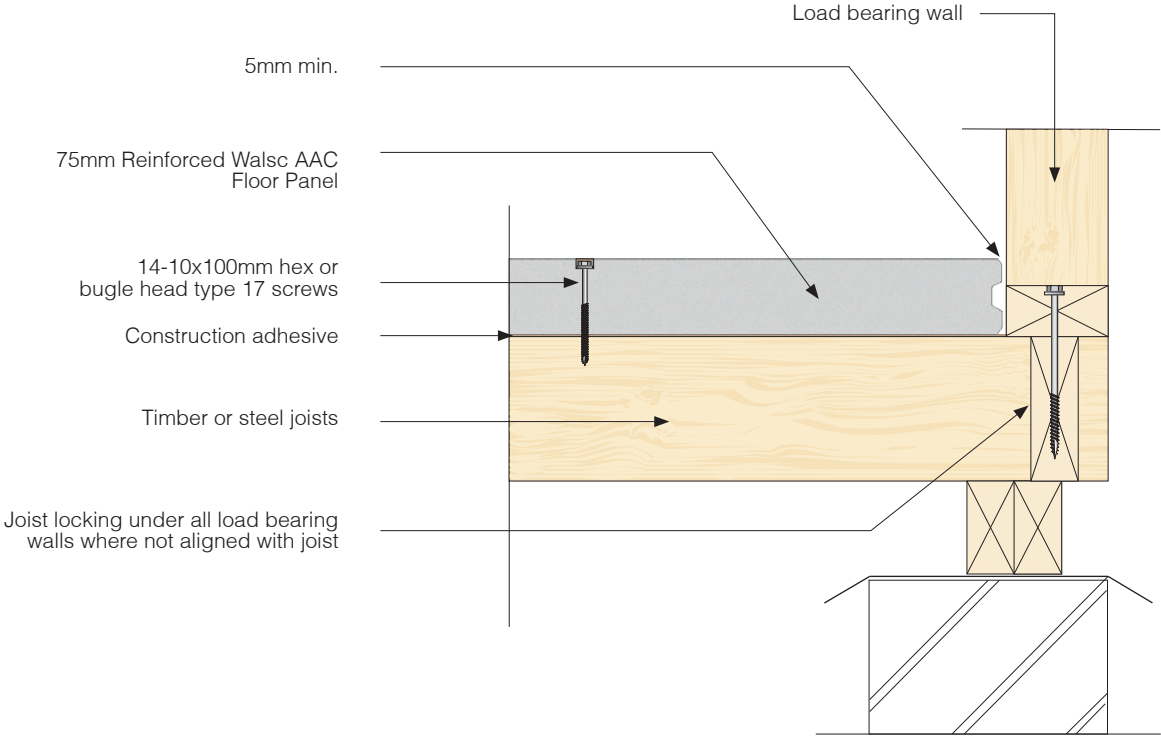
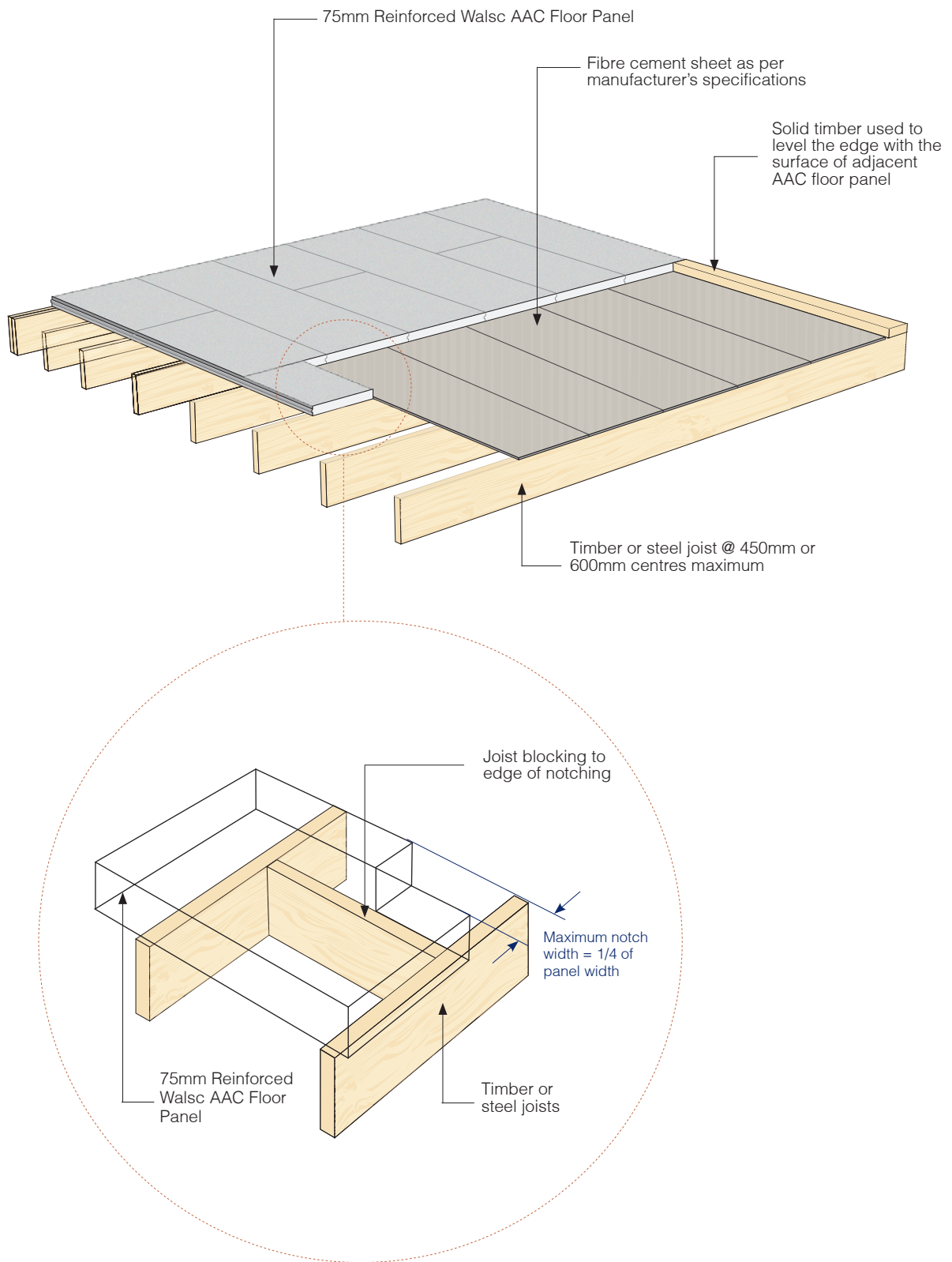
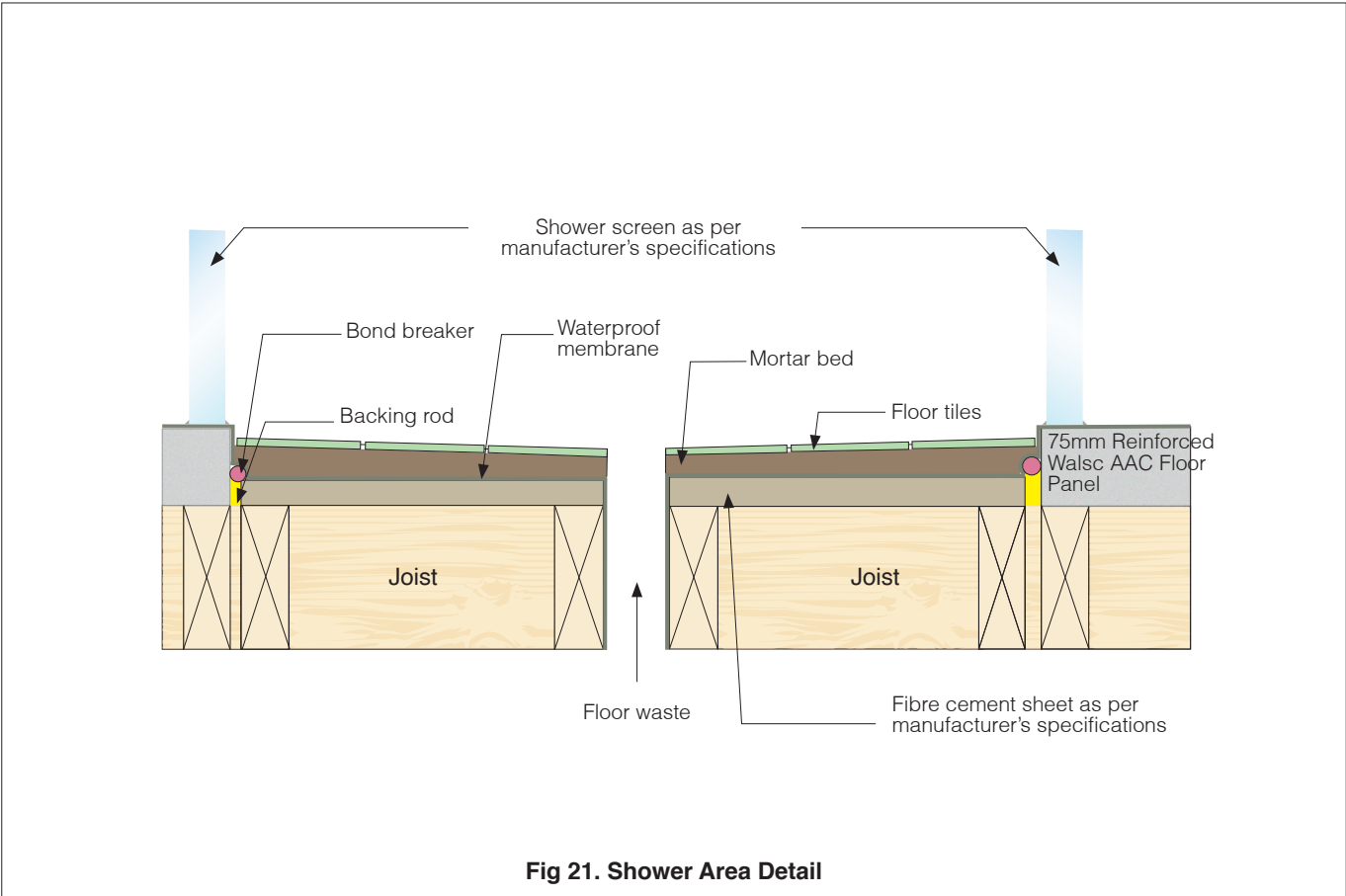
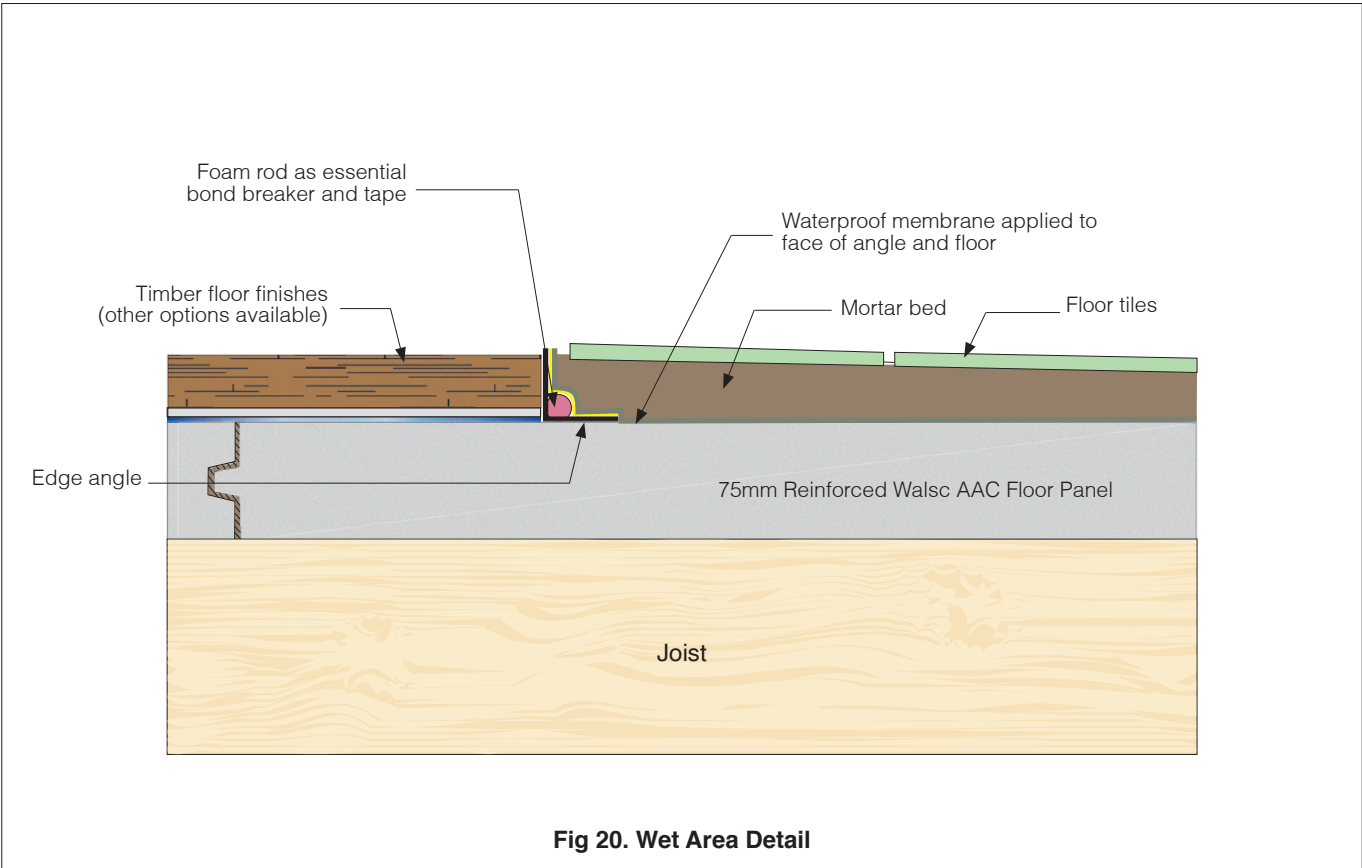







Fig 18. Fitted Floor Panel at External Wall Detail



**Fig 19. Blocking Detail for Corner Notching**



**Use Walsc products in low-rise and multi-residential buildings as a better wall or flooring solution.**

-  External Wall Cladding System 50
-  External Wall Cladding System 75 Light
-  Inter-tenancy Wall System 50
-  Inter-tenancy Wall System 75 Light
-  AAC Flooring System

## **Sipo Building Solutions Pty Ltd**

ABN: 46 614 424 225

25 Pike Street  
Rydalmere, NSW 2116

19 Warehouse Cct,  
Yatala, QLD 4207

T 02 9748 2832

F 02 8246 3486

Technical Support:

1300 957 566

[info@sipo.com.au](mailto:info@sipo.com.au)

[www.walsc.com.au](http://www.walsc.com.au)

The latest version of this guide  
is available at [walsc.com.au](http://walsc.com.au)

### **Disclaimer**

This design guide has been carefully prepared for general guidance only and not intended to be a substitute for the exercise of professional judgment. The information presented in this guide should not be construed as legal, technique, or any other professional advice or service. It is the user's responsibility to confirm the suitability of Walsc products in particular circumstances. Since the application based on the contained information in this document may be beyond our control, neither Walsc nor any of its directors or employees should accept responsibility for loss or damage occasioned to any person acting or refraining from action as a result of inappropriate use of the information. Sipo Building Solutions Pty Ltd reserves the right to alter or update inclusive information from time to time with or without notice.